

MODEL: APIPC6048B22B

ALL ACCESSORIES OPTIONAL

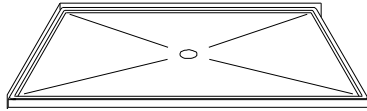

**PERSPECTIVE VIEW - N.T.S.
MODEL SHOWN HERE AS:
LEFT HAND SHOWN**

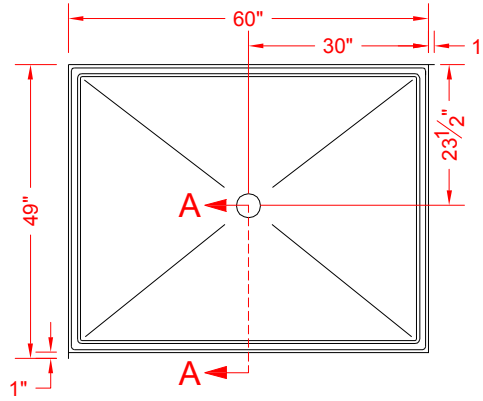

TOP VIEW - SCALE $\frac{3}{8}'' = 1'-0''$



BARRIER FREE

Features:

- Molded, one piece gelcoat/fiberglass shower pan
- Accessible fiberglass corner shower pan
- 1/2" Threshold keeps water inside
- On all threshold, heights 1-1/2" or taller, no mud set is required

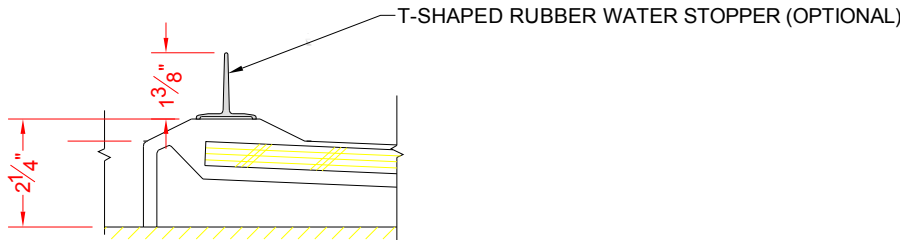

SECTION A-A - SCALE: 3" = 1'-0"

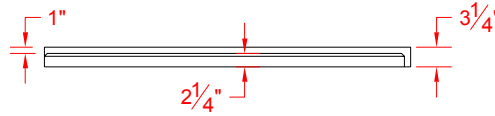

FRONT ELEVATION - SCALE: $\frac{3}{8}'' = 1'-0''$

PRODUCT SPECIFICATIONS:

- One piece corner shower pan shall be constructed of gelcoat/fiberglass
- Rough-In: Stud opening +1/4" -0" Nominal Dimensions.

C.S.I. FORMAT SPECIFICATION TEXT AVAILABLE

PRODUCT INFORMATION:

- Colors: White as standard, others to match any major fixture manufacturer, also available with sprayable solid surface in many colors

ACCESSORIES:

INSTALLED BY OTHERS:

- Collapsible Rubber Water Retainer
- Caulkless drain

CODES:

Designed and manufactured in compliance with the following standards and codes:

- A.N.S.I. Z124.2 Standards for Plastic Showers
- I.P.C. International Plumbing Code
- U.P.C. Uniform Plumbing Code

NOTICE OF LIMITATION:

1-877-947-7769
www.Accessible-Bathrooms.com

We reserve the right to make revisions without notice in the design of fixtures or in packaging unless this right has specifically been waived at the time the order is accepted.